



SEPTEMBER 2021

SONO LIVE

Development Update

SONO  MOTORS

Today's Experts



MARKUS VOLMER

CTO

-
- Previously at: Daimler, Foton Motor



MITCHELL ZARDERS

INFOTAINMENT DEVELOPMENT

-
- Previously at: Hyundai / Kia Toyota



LEONHARD SAIBEL

BODY STRUCTURE

-
- Previously at: Italdesign, EDAG, Bertrandt



BENE ZEILBERGER

THERMAL

-
- 3 years experience at Sono Motors



SERHAN SEZER

INTERIOR / SAFETY

-
- Previously at: Ford (10 years)
 - 3.5 years experience at Sono Motors



SEBASTIAN BÖTTGER

COMMUNITY-BEIRAT

-
- Entrepreneur
 - Software developer
 - Community member advisor since 2020

SONO UPDATE

Agenda

01 DEVELOPMENT UPDATE (DESIGN RELEASE)

10 MIN

02 INFOTAINMENT

5 MIN

03 BODY STRUCTURE

5 MIN

04 SAFETY

5 MIN

05 THERMAL

5 MIN

06 Q&A

30 MIN

Q&A

Slido

<https://app.sli.do/event/yeyluz1m>



01 SONO MOTORS

Development Update (Design Release)

DEVELOPMENT UPDATE

PLANNED SOP H1 2023

DEVELOPMENT PLAN

Prototype Series on the Way to Series Production

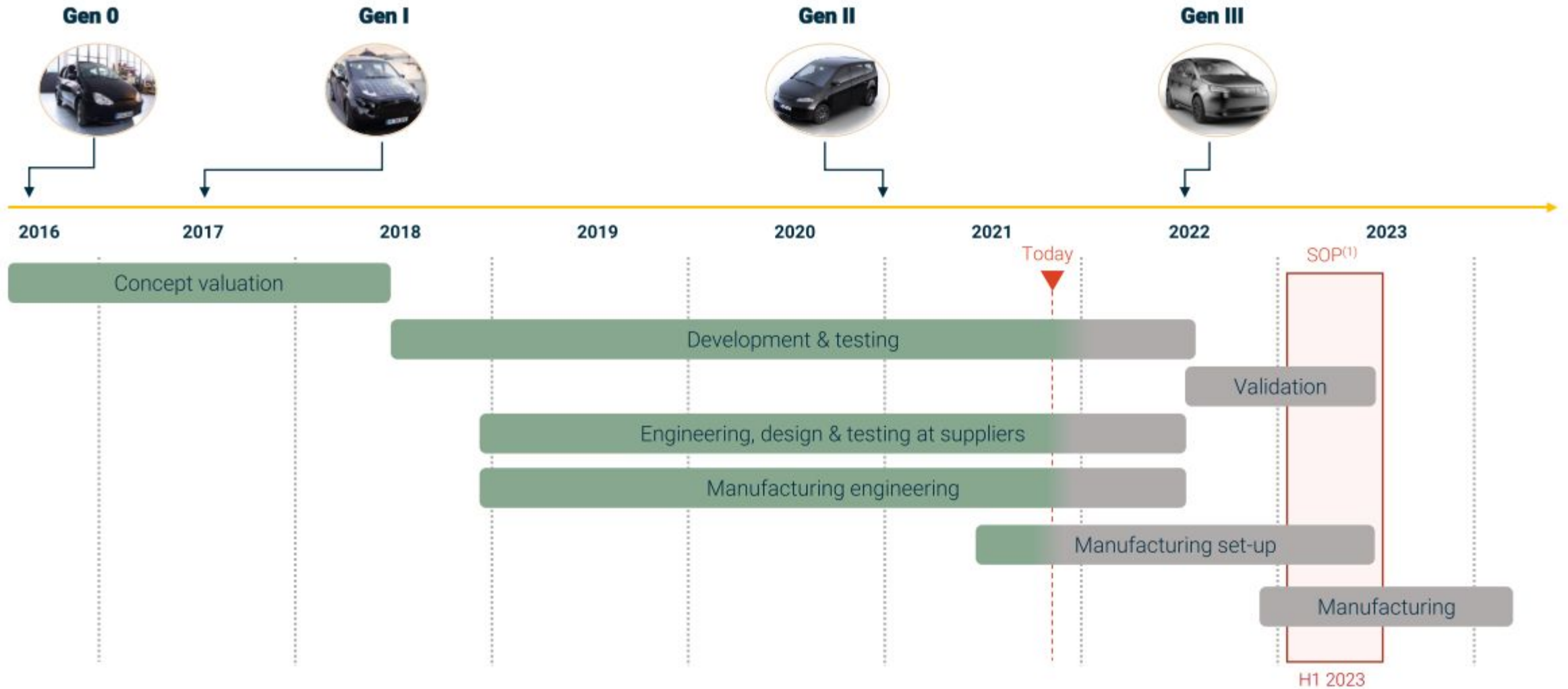

TERMS DEFINITION

Design Release (DR)

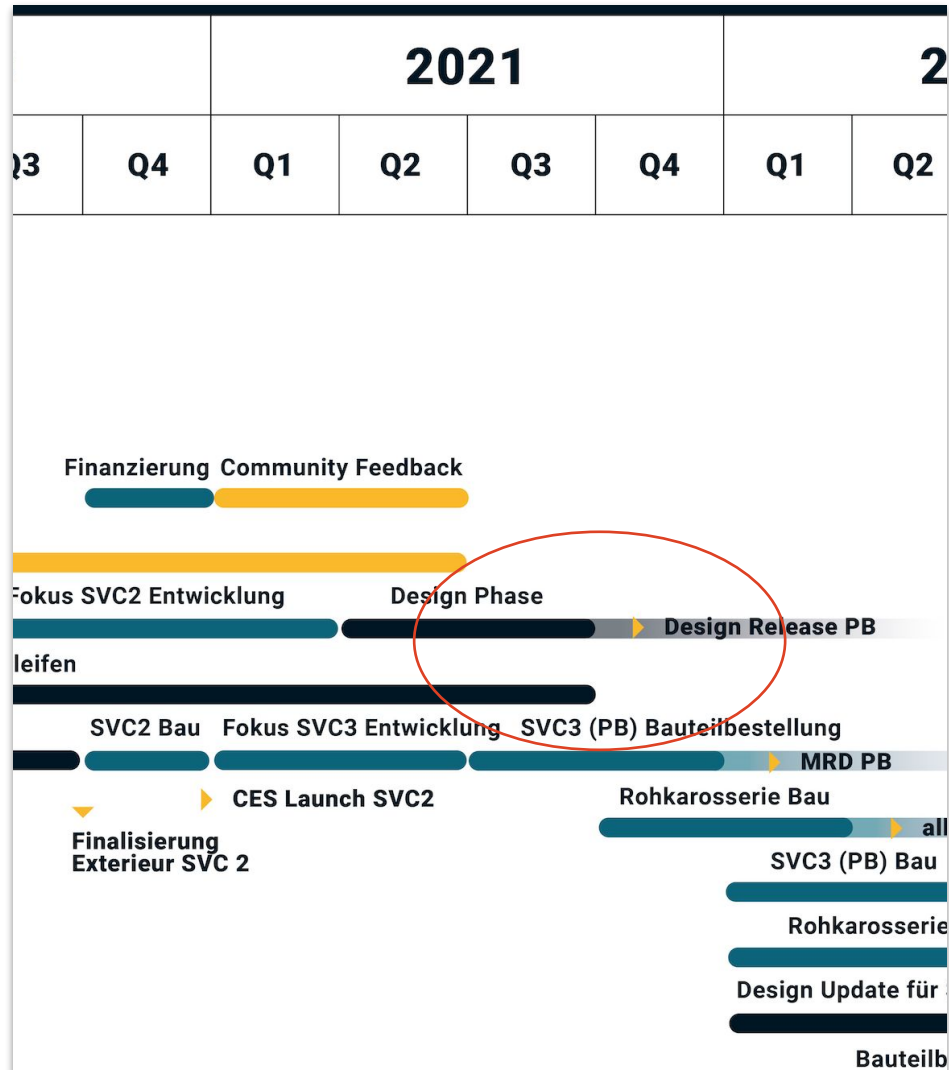

01

Development complete/

Long term tools commissioned/
Suppliers receive purchase orders/
Exact part costs are known.

02

No further changes to the vehicle are planned
(only if testing is required).

03

Production feasibility is guaranteed for each
component.

04





















Crash & Safety – simulations show good to very good
results

05

Homologation – all requirements for the vehicle and its
components must be met

DESIGN RELEASE MILESTONES

Current Status: SVC3 Design Release

AREA	SVC3 STATUS Design Release 09.21	SVC3 MATERIAL Required Date (MRD) 03.22	COMMENTS
BODY			SVC3 DR + 12 weeks; Many interfaces (fixtures, assembly points) are still open (interior, exterior etc.). 3D data cannot be frozen until DR.
INTERIOR & SAFETY			Further negotiations with some suppliers necessary.
DOORS & TRIM			Some providers are missing. DR is expected to be in Nov '21.
EXTERIOR			3 nominated suppliers. Essentially 2 missing suppliers (underbodies, wheel arch liners). MRD is expected to be in Nov '21. Bumpers will arrive about 7 weeks after MRD date.
THERMAL			All interfaces are defined for the DR. Important parts are takeover components and are being procured. No orders have yet been placed for pipes, hoses, air ducts and sensors.
CHASSIS			The supplier for the steering system has not yet been determined.
ELECTRICS / ELECTRONICS			Some suppliers are missing. Device transmittal 1 month late. New requirements from infotainment, ASiL and FuSa received, affecting schedule and development.
MOTOR			There are still a few suppliers missing.
INFOTAINMENT			The only system that could be delayed is the head unit. For each system, 5 samples have been ordered for testing purposes.
HV BATTERY			Everything is sourced from the supplier. DV under detailed planning.

DEVELOPMENT UPDATE

**The development strategy
was adjusted so as not to
delay SOP.**

NECESSARY TO KEEP SOP

Adaptation of Development Strategy



WHAT REMAINS THE SAME?

- SOP H1 2023
- SVC3 H1 2022
- SVC3 is almost identical to series
- Manufacture at NEVS



WHAT CHANGES?

- SVC3 component release will become “phase” by 12/21
- First lot of 11 x SVC3 in spring 2022
- Mix of soft and hard tools in interior and exterior production



WHICH RISKS ARISE?

- Early release for long term parts
- Additional costs in production







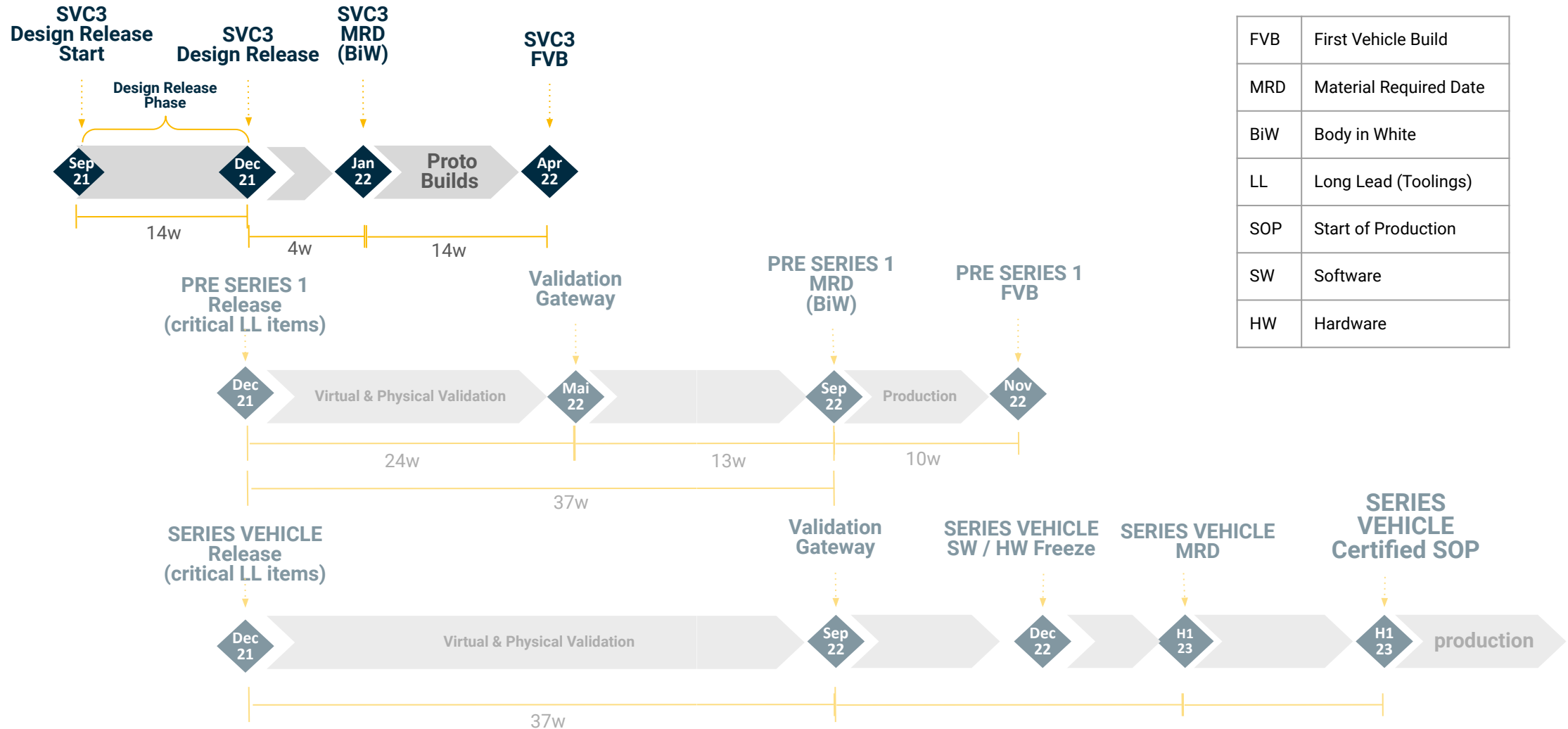

























CURRENT TIME PLAN

Sion Timing Overview



DESIGN RELEASE MILESTONES

Current Status: SVC3 Design Release

AREA	SVC3 STATUS Design Freeze 09.21	SVC3 MATERIAL Required Date (MRD) 03.22	DR STATUS AFTER STRATEGY ADAPTATION
BODY			
INTERIOR & SAFETY			
DOORS & TRIM			
EXTERIOR			
THERMAL			
CHASSIS			
ELECTRICS / ELECTRONICS			
MOTOR			
INFOTAINMENT			
HV BATTERY			



PRODUCTION PARTNER UPDATE

**NEVS remains our production partner for the Sion.
All Sion reserved to date will be produced in 2023.**

MITCHEL ZARDERS

Infotainment Development



INFOTAINMENT

Design Release



HIGHLIGHT

- Design Release for all critical components
- All components set to be delivered for bench testing 01.12.2021
- Parts will be available for LabCar



IN PROGRESS

- Ramp up staff for hardware and software development
- Accessing two suppliers for Ecall button hardware



LOW LIGHT

- World wide chip shortage “may” have in impact on purchasing timing
- Need to finalize steering wheel supplier (mapping buttons for IHU & IC interface)





FEATURES

Infotainment System Specs

FEATURES:

- **Core processor: NXP i.MX 8QuadMax**
- Antennas FM/DAB/WiFi/BT/LTE/GPS
- **Wireless Apple CarPlay & Android Auto**
- **Android Automotive 11 OS**
- **Custom, in-house developed the infotainment UI**
- Bluetooth hands free
- **Custom designed hypervisor in head unit (virtual machine manager)**
- Front USB interface (27W charging and data)
- Rear USB (15W charging only)
- **Four channel 250W internal amp**
- **Infotainment OTA (over the air updates)**
- 25.6cm CID touch display / 26cm IC TFT display
- **Six speakers**
 - **Dash 2 x 2.5cm tweeter**
 - **Ft door 2 x 16cm woofer**
 - **Rr door 2 x 12.7cm full range speaker**





LEONHARD SAIBEL

Body

BODY

Final design release planned for end of November 2021



HIGHLIGHT

- Pre-release of 3D data SVC3 already ready in KW40 ✓
- NVH requirements almost met ✓
- Feasibility of individual parts checked ✓
- Fügefolgen seitens Produktion bestätigt ✓
- Gewichtsreduzierung durch Optimierung der Bauteile ✓



IN PROGRESS

- Further crash optimizations up to DR and to increase the degree of maturity.
- Bolts for grounding (earth bolts) are not yet finally defined



LOW LIGHT

- Mounting concept for roof module and sun visors not yet confirmed



BODY

Weight Optimization Example (approx. -3kg)

- Weight optimization
 - 1 large component divided into several smaller parts
 - Identical parts can be installed on the envelope -> lower parts variation

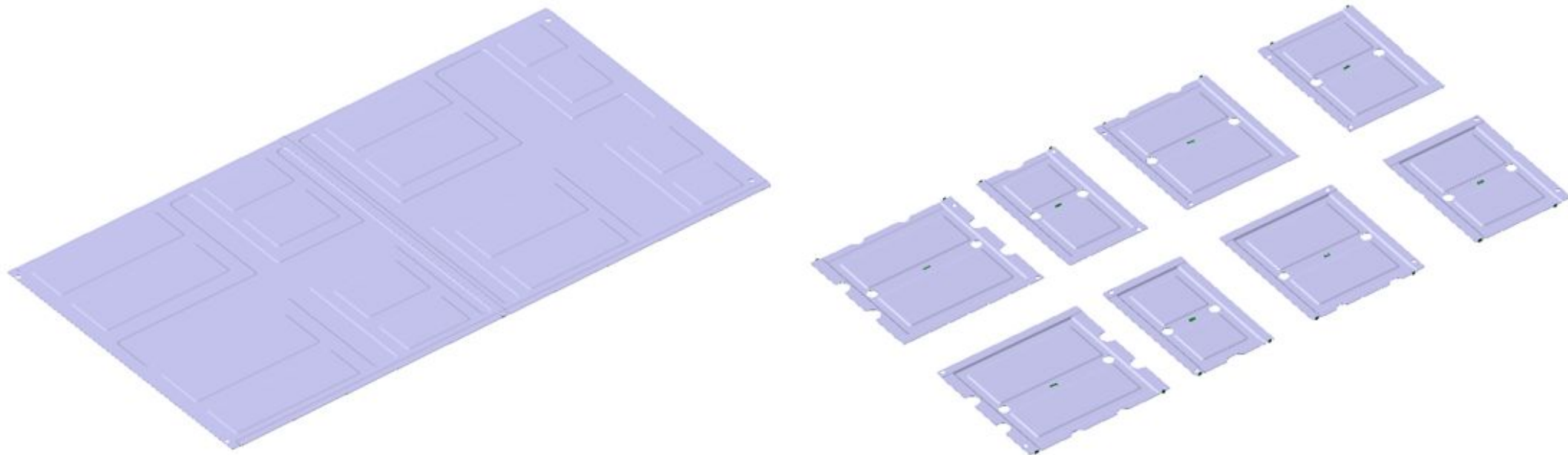

BODY

Critical Long-Term Parts – Tool Running Times up to 65 Weeks

(Potential for reduction to 54 weeks)

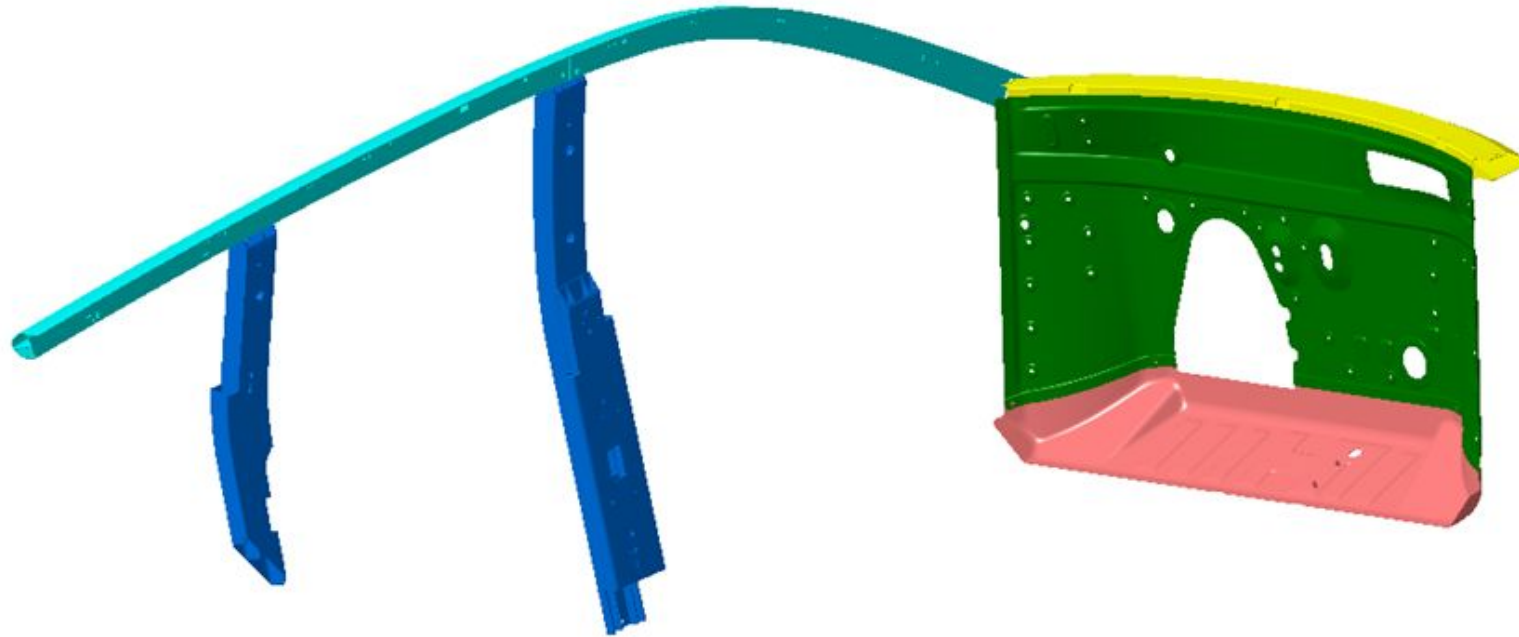



SERHAN SEZER

Crash & Safety

Design Release



HIGHLIGHT

- Extension of front-end ✓
- Structural crash targets considering the new HV Battery ✓
- Low-speed damageability assessment for insurance classification ✓
- Structural crash assessments ✓
- Development of the passenger safety targets ✓



IN PROGRESS

- Integration of restraint systems
- HV safety and rescue assessments
- Model assumptions in vehicle simulation model
- PedPro: PV integrated hood
- Structural crash assessment counter measures
- Pedestrian protection assessments
- Adaptation of new HV Battery



LOW LIGHT

- Multi-interface charging lid in the front
- No physical testing done so far
- Timing between design releases and physical vehicle crash tests



CRASH & SAFETY

2020

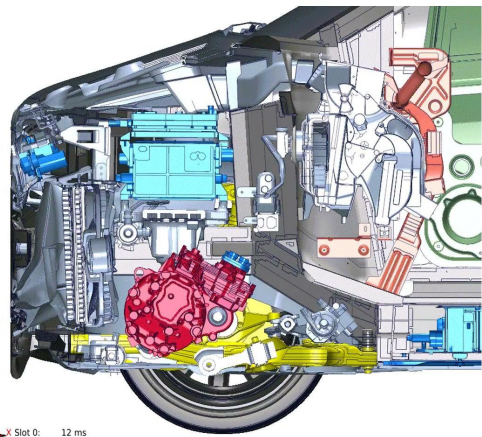
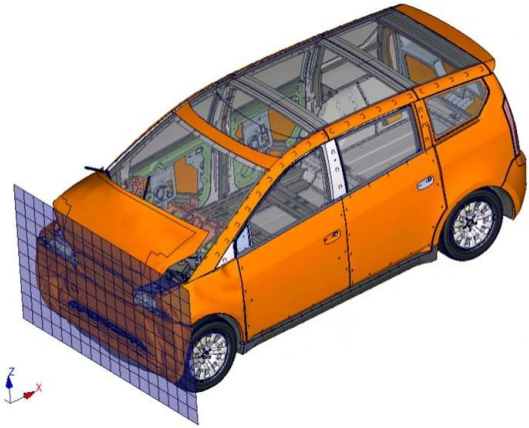

X Slot 0: 12 ms

2021

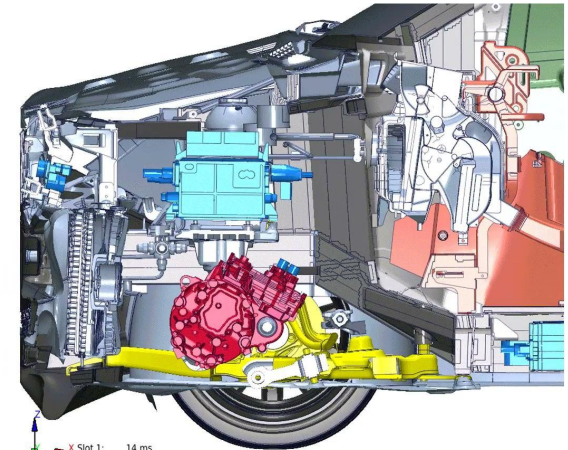
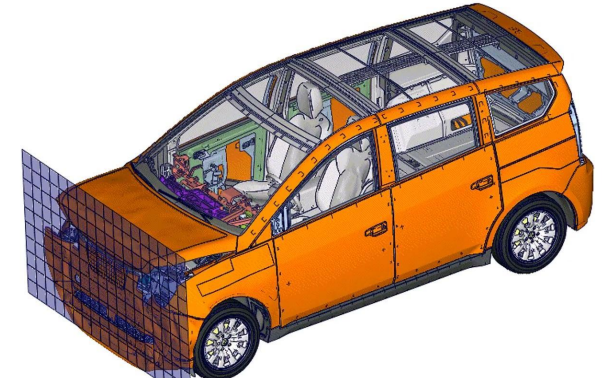

X Slot 1: 14 ms

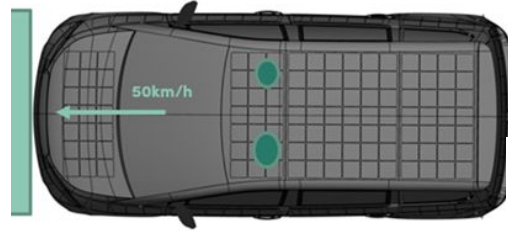

ECE R137 – Full Frontal



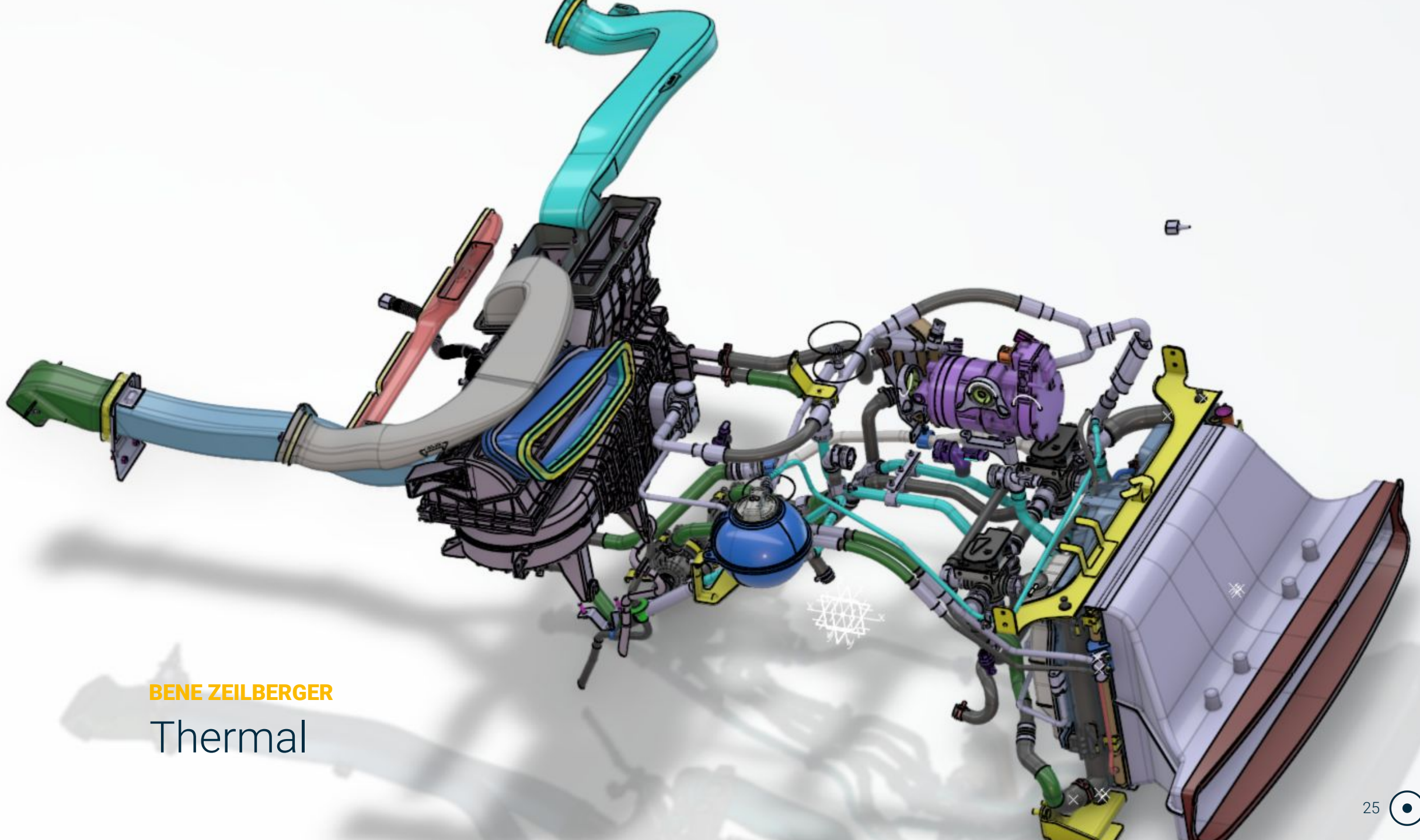

BENE ZEILBERGER

Thermal







THERMAL

Design Release



HIGHLIGHT

- CO suppliers are ready for the SVC3 
- All components in the installation space (reactive changes still possible) 
- Design of the lines manufacturable 
- CAE simulations of the holders in order 



IN PROGRESS

- 54 kWh battery created additional workload
- New supplier needed for the coolant pump
- High workload due to small parts (seals, screws, clips)



LOW LIGHT

- Coolant level sensor



FEATURES OF THE THERMAL SYSTEM

Technical Data Overview

- Liquid cooling (cooling agent: water-glycol mixture) for EDU (motor), OBC (on board charger) and HV battery
- Interior heating via coolant -> waste heat utilization possible
- HV heater (400V) with 5 kW heating power for interior and battery
- Pre-conditioning possible (interior and battery)
- Classic air conditioner with connection to battery cooling: refrigerant R1234yf
- Strong performance, high efficiency, comparatively inexpensive

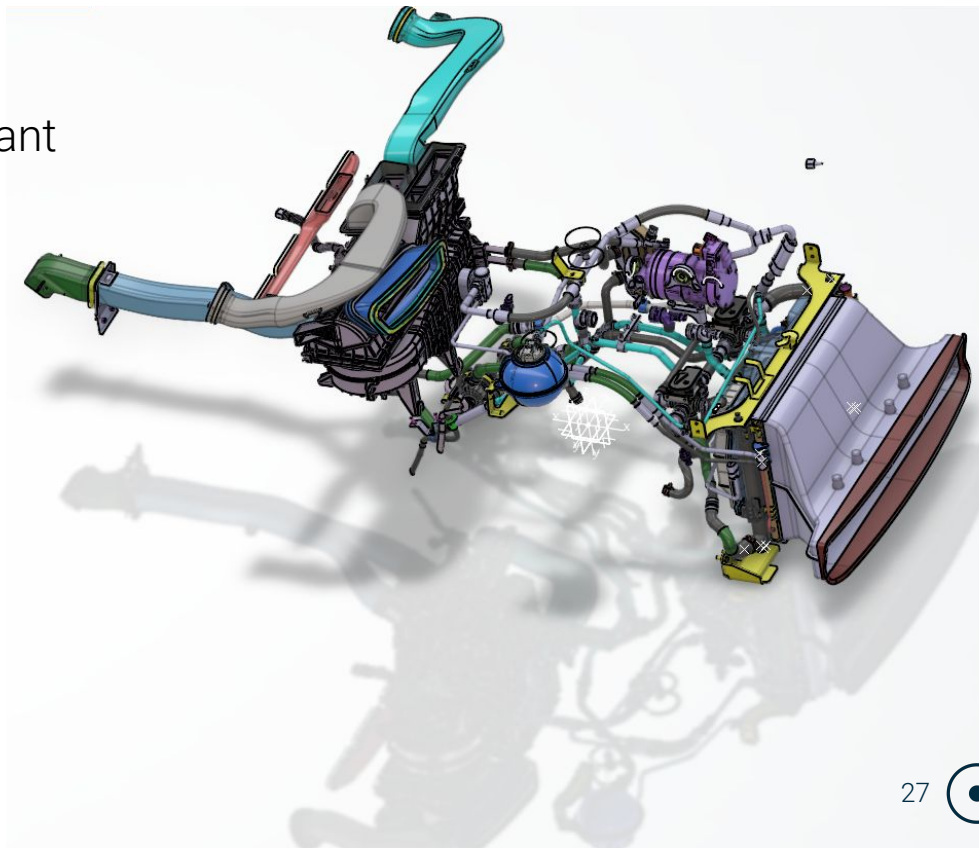

THE BEST FOR LAST

**THANK YOU,
COMMUNITY!**



OUR VISION

A WORLD WITHOUT FOSSILE FUELS.



QUESTIONS ANSWERS



oligo 2018
preisträger deutscher mobilitätspreis

N FUTURE 50



SONO MOTORS GMBH

Waldmeisterstrasse 76
80935 Munich | Germany
T +49 (0)89 45 205 818

E info@sonomotors.com

W sonomotors.com

VAT DE305560734

District Court Munich HRB 224131

Managing Directors: Laurin Hahn & Jona Christians

© Sono Motors 2021

